



**CHAM Limited**  
*Pioneering CFD Software for Education & Industry*

## PHOENICS Case Study

### Fire & Smoke Simulation in a Multi-Storey Underground Car Park

One of the many examples of PHOENICS-based fire and smoke simulation models concerned a proposed multi-storey underground car park located in the Netherlands.

The car park is 20m in diameter, and 22m high. It has a circular form with a spiral access ramp surrounding a central region, open to all floors, reaching up to a slightly domed roof. Access is gained from ground level with parking on all seven levels below.

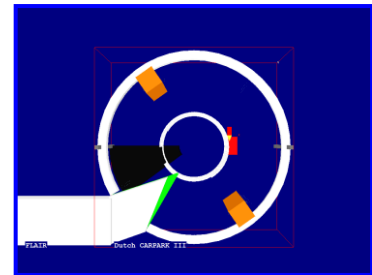
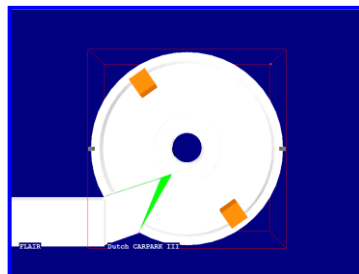
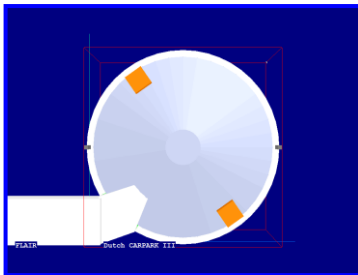
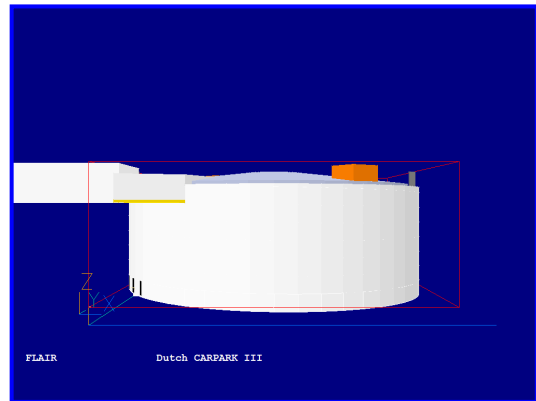

The study, undertaken by Dutch consulting firm, Excelair BV, models the effect of the spread of smoke to other floor levels resulting from a car fire located on Level 6. The entire car park uses a fan-assisted system for ventilation and fire control, combined with a sprinkler installation.

In this scenario, the sprinkler model uses:

- a water temperature of 15 degrees Celsius;
- an average water droplet size specified as **????**;
- a volume flowrate of litres/min 56 litres per min;
- a spray angle (or "footprint") of 12m<sup>2</sup>. 30% of the water is directed down with 70% coming out horizontally from the sprinkler head; and
- an activation time of 180 sec after the car fire starts.

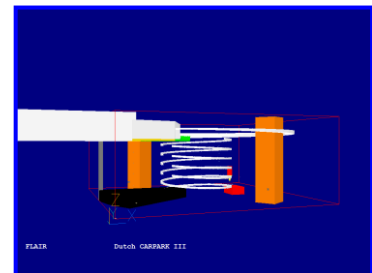



The sprinklers are confined to the vicinity of the car fire, which is specified as 8.3 MW and treated as a source of heat and pollutant. In such a fire scenario, the air-flow from the jet fans are increased with the intention to clear smoke and provide good visibility to the emergency exits.

The case was run in two parts; from time 0-180 seconds, during which the sprinklers remained inactive, and then from time 180-1200 seconds following activation.

Conclusion: The study showed ...

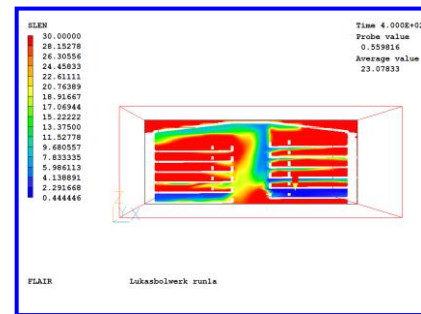
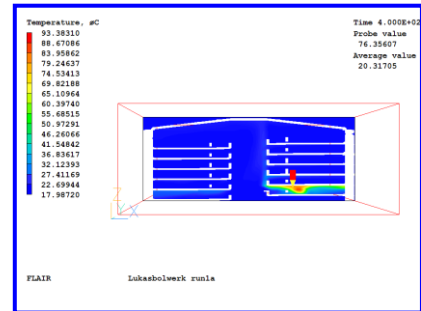

---

CHAM Ltd, Bakery House, 40 High Street, Wimbledon Village, London SW19 5AU, UK  
Tel: +44 (0)20 8947 7651 Fax: +44 (0)20 8879 3497 Email: [phoenics@cham.co.uk](mailto:phoenics@cham.co.uk)  
Web: <http://www.cham.co.uk>